



**PROCEEDINGS OF  
THE SECOND INTERNATIONAL CONFERENCE  
ON  
SCIENCE AND ENGINEERING**

*Volume - 1*

**Electronics  
Electrical Power  
Information Technology  
Engg: Physics**

**Sedona Hotel, Yangon, Myanmar  
December 2-3, 2010**

**PROCEEDINGS OF THE  
SECOND INTERNATIONAL CONFERENCE  
ON  
SCIENCE AND ENGINEERING**

**Organized by  
Ministry of Science and Technology**

**DECEMBER 2-3, 2010  
SEDONA HOTEL, YANGON, MYANMAR**

# Design and Simulation of Down Conversion Mixer for Front-end Portion of Satellite Receiver

Hnin Yu Wai<sup>#1</sup>, Zaw Min Naing<sup>\*2</sup>, Kyaw Soe Lwin<sup>#3</sup>

<sup>#</sup>Mandalay Technological University, Mandalay, Myanmar

<sup>\*</sup>Technological University (Maubin), Myanmar

<sup>1</sup>powerlay@gmail.com, <sup>3</sup>kyawsoelwin007@gmail.com

<sup>2</sup>zawminnaing@pmail.ntu.edu.sg

**Abstract**— In this paper, design and simulation of receiver analogue front-end portion (downconversion mixer) of satellite ground station is presented. The receiver chain is designed to down convert and band pass filtering required for the front-end portion. In this design, the Radio Frequency (RF) and Local Oscillator (LO) frequencies are filtered at 20GHz and 19.5GHz which offers an Intermediate Frequency (IF) of 500MHz. The output IF value can meet the requirements of ultra-wide band receiver analogue front-end portion. The conversion gain for the proposed mixer design is evaluated. The simulation results show input signals and output signal of the mixer.

**Keywords**— front-end, downconversion mixer, IF, Ka-band

## I. INTRODUCTION

The rapid growth of wireless communication such as cordless and cellular phones, wireless local area networks, global positioning satellite (GPS) requires higher performance which has increased the demand for low-cost RF front-end receivers. New technologies are improved to increase higher data rates and capacity. There are a number of different ways that satellite receivers can be designed. But, this paper concentrates on superheterodyne architecture only.

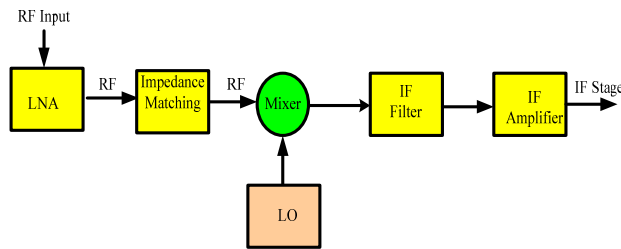

Fig. 1 RF front-end

Fig. 1 shows the block diagram of a typical RF receiver front-end portion. A superheterodyne architecture is used to translate an RF signal down to intermediate frequency(IF), where filtering of adjacent interferer signals as well as amplification and gain control of the target signal is more practical. In the superheterodyne radio, low noise amplifier (LNA) raises the very weak radio frequency (RF) signals to a more convenient level for future processing. Then, the received RF signal enters one input of the mixer. A locally

generated signal (local oscillator signal) is fed into the other. The result is that new signals are generated. These are applied to a fixed intermediate frequency (IF) amplifier and filter. Any signals that are converted down and then fall within the passband of the IF amplifier will be amplified and passed on to the next stages. The signals that fall outside the passband of the IF filter are rejected.

Channel selection and amplification occurs at IF. The target signal is selected from among the other signals via one or more passive filters. The IF amplifier is responsible for providing most of the gain in the receiver, as well as the narrowest band pass filtering. It is a high gain, usually multi-staged, single frequency tuned radio frequency amplifier [1].

This paper is divided into five parts. Section II discusses about the front-end portion of satellite receiver. Section III describes downconversion mixer design. The aim is to optimize the performance of down conversion mixer to make it useful for applications around an RF frequency equal to 20GHz. The conversion gain has to be tuned to acquire an acceptable value and make the linearity as high as possible for compensation. Then, Section IV gives the simulation results of downconversion mixer. Finally, Section V presents the conclusion.

## II. FRONT-END PORTION OF SATELLITE RECEIVER

The front-end of a modern superheterodyne radio receiver is the circuitry between the antenna input terminal and the output of the first mixer stage. So, the front-end section consists of Low Noise Amplifier (LNA), Mixer and IF Filter / Amplifier.

### A. Low Noise Amplifier

The low noise amplifier (LNA) is the first amplifier in the system. It raises the very weak radio frequency (RF) signals to a more convenient level for future processing. The LNA must have a low noise figure (NF) in order to prevent an excessive degeneration of the signal to noise (S/N) ratio as well as the completely loss of the weak input radio signal. The amplified signal then enters one port of the mixer.

An LNA design presents a considerable challenge because of its simultaneous requirement for high gain, low noise figure, good input and output matching and unconditional stability at the lowest possible current draw from the amplifier. Although Gain, Noise Figure, Stability, Linearity and input and output matching conditions are all equally

important, they are interdependent and do not always work in each other's favour.

### B. Mixer

The mixer is a very important circuit in satellite receiver as its performance affects the system performance and the performance requirements of its adjacent circuit such as low noise amplifier and the IF amplifier. Mixers are used to translate a signal spectrum from one frequency to another by using nonlinear devices, such as diodes, transistors or field-effect-transistor (FET) mixer in time-varying circuits. The output of the mixer contains the sum and different frequencies of the LO signal and an incoming information signal, the RF signal.

Mixers can be divided into three types according to their topologies. They are single-ended, single-balanced, and double-balanced. This paper concentrates on singled-ended mixer only. In addition, it can be categorized into passive and active mixers in terms of conversion gain. Passive mixers, such as diode mixers and passive field-effect transistor (FET) mixers, have no conversion gain. On the other hand, active mixers have conversion gain which acts to reduce the noise contribution from the IF stages. Downconversion mixer should provide sufficient power gain to compensate for the IF filter loss, and to reduce the noise contribution from the IF stages. Because the receiver gain can be supported by the LNA, high conversion gain for the Mixer is not often needed [2].

### C. IF Filter / Amplifier

The output of the frequency translator or downconversion mixer is called the intermediate frequency (IF). The main attribute of the superheterodyne receiver is that it converts the radio signal's RF frequency to a lower standard IF frequency for further processing. The reason is that higher frequencies were more difficult to process than lower frequencies.

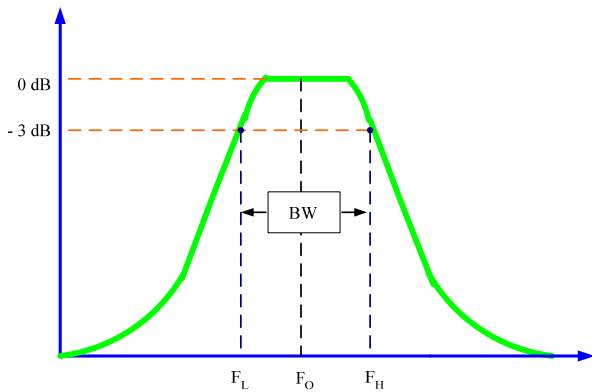

Fig. 2 IF bandwidth response

The two frequencies that are generated at the output of the mixer are then fed into a fixed frequency intermediate frequency (IF) amplifier and filter. Since the mixer's IF port is terminated with a conventional IF filter, such as bandpass or

lowpass type, the sum frequency re-enter the mixer and generate intermodulation distortion. Any signals that are converted down and then fall within the passband of the IF amplifier will be amplified and passed on to the next stages. Those that fall outside the passband of the IF filter are rejected.

Most of the selectivity of the receiver is provided by the filtering in the IF amplifier section. The filtering might be L-C filters, a ceramic resonator, a crystal filter or a mechanical filter. The intermediate frequency (IF) bandwidth is measured from the points on the IF frequency response curve where gain drops off -3dB from the mid-band value. Figure 2 illustrates this. The intermediate frequency (IF) bandwidth must be matched to the bandwidth of the received signal for best performance. If the wider signal bandwidth is selected, the signal to noise ratio (SNR) will deteriorate and then the received signal may be noise. If the bandwidth is too narrow, then it may be experienced the difficulties for recovering all of the information that was transmitted [1].

### III. DOWNCONVERSION MIXER DESIGN

DownConversion mixers perform frequency conversion by using nonlinear elements in time-varying circuits. The basis of mixing relies on the multiplication of two signals: an ideal square wave, the local oscillator signal and an incoming information signal, the RF signal.

When two signals are multiplied together the output is the product of the instantaneous level of the signal at one input and the instantaneous level of the signal at the other input. It is found that the output contains signals at frequencies other than the two input frequencies [3]. If the two input signals are referred to as  $V_1$  and  $V_2$  in Eqs. (1) and (2),

$$V_1 = A_1 \sin(\omega_1 t) \quad (1)$$

$$V_2 = A_2 \sin(\omega_2 t) \quad (2)$$

The output is according to the (1) and (2) as following:

$$V_o = V_1 V_2 = A_1 A_2 [\cos(\omega_1 - \omega_2)t - \cos(\omega_1 + \omega_2)t] / 2 \quad (3)$$

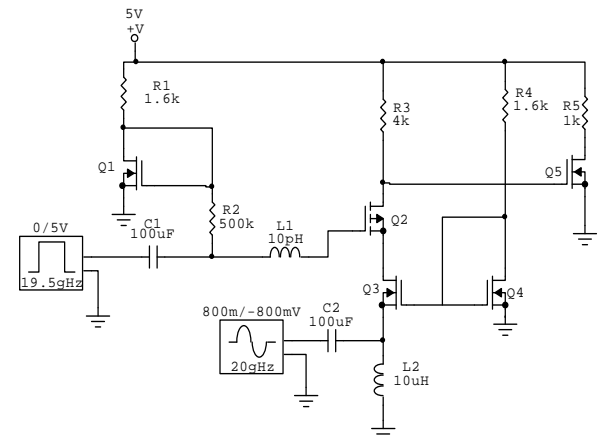

Fig. 3 Schematic circuit diagram of mixer

The output contains the sum and different frequencies of the two input signals. For downconversion purpose, the sum

signal must be filtered out by IF filter. Figure 3 shows the circuit diagram for the proposed mixer schematic. From this diagram, the mixer core is  $Q_2$ . It is used to commutate the RF signals. The operation point (Q) of  $Q_2$  must be biased in the proper saturation region and it must be close to the triode region. The DC biasing represents the first step in the mixer design.  $R_1$ ,  $R_2$  and  $Q_1$  forms the biasing circuit for the transistor  $Q_2$  and  $R_4$  and  $Q_4$  forms the biasing circuit for transistor  $Q_3$ [4].

The mixing operation is performed by modulating transconductances of the driver stages with the local oscillator signals. By varying the drain-source voltage  $V_{DS}$  of  $Q_3$ , the local oscillator signal modulates transconductance of the driver stage. The drain of  $Q_3$  is typically biased at the edge between triode and saturation regions so as to maximize the variation of transconductance due to the local oscillator signal. The voltage of the RF signal is amplified and converted into a current by a driver stage. Finally, the IF output voltage is created due to the current through the load resistors. For the LO switching case, LO is the square wave while the RF signal is sinusoidal:

$$V_{LO}(t) = \frac{4}{\pi} \cdot \cos\omega_0 t - \frac{4}{3\pi} \cos(3\omega_0 t) + \dots \quad (4)$$

For a sinusoidal RF signal,

$$V_{LO}(t) \times V_{RF}(t) = \frac{2A_{RF}}{\pi} \cdot \cos(\omega_{RF} - \omega_0) t + \dots \quad (5)$$

The current of RF can be defined as

$$I_{RF}(t) = V_{RF}(t) \times g_m = V_{RF} \sin(\omega_{RF} t) \times g_m \quad (6)$$

The output current IF is the product of RF current and local oscillator signal. Therefore,

$$\begin{aligned} I_{IF}(t) &= I_{RF}(t) \times V_{LO}(t) \quad (7) \\ &= \frac{2}{\pi} \times g_m \times V_{RF} \times \cos(\omega_{RF} - \omega_{LO})t \end{aligned}$$

Conversion gain ( $G_c$ ) is the ratio of the output signal to input signal which can be voltage, current or power. So, the voltage conversion gain equation of the proposed Mixer is as follows,

$$G_C = \frac{V_{IF}}{V_{RF}} = \frac{2}{\pi} \times g_m \times R_3 \quad (8)$$

where,  $g_m$  is the transconductance of  $Q_3$  and  $R_3$  is the load resistance. Through the state of saturation of FET formula, the equation of transconductance is given by

$$g_m = \sqrt{2 \cdot \mu_n c_{ox} \cdot \frac{W}{L} \cdot I_D} \quad (9)$$

$$c_{ox} = \frac{\epsilon_{rf} \epsilon_0}{t_{ox}} \quad (10)$$

$$I_D = \frac{\mu c_{ox}}{2} \cdot \frac{W}{L} \cdot (V_{GS} - V_T)^2 \quad (11)$$

Table1 presents the calculated results for biasing circuits of mixer circuit. Table2 describes the calculated results for the conversion gain at IF out.

Impedance matching is the next important step in the mixer design. In the mixer circuit, the transistor  $Q_3$  will be chosen to support the RF input match and isolation from the RF signal port to IF port at 20 GHz. Therefore,  $C_2$  and  $L_2$  were chosen to ensure that they provide input impedance of 50  $\Omega$  and resonate at 20 GHz. The local oscillator port input match consists of  $L_1$  and  $C_1$ . It is matched to an impedance of about 50  $\Omega$ . Without proper matching, the power loss directly degrades the performance of the power gain and the signal-to-noise ratio.

TABLE I  
CALCULATED RESULTS FOR BIASING CIRCUIT OF MIXER

$V_t$	$V_{gs}$	$U_n \cdot c_{ox}$	$W/L$	$I_d$	$V_{dd}$	$V_{ds}$	$g_m$	$R_l$
0.7	2.5	0.00005	10	0.00081	5	1.8	0.0009	3950.6
0.7	2.6	0.00005	10	0.00090	5	1.9	0.00095	3434.9
0.7	2.7	0.00005	10	0.001	5	2	0.001	3000
0.7	2.8	0.00005	10	0.00110	5	2.1	0.00105	2630.3
0.7	2.9	0.00005	10	0.00121	5	2.2	0.0011	2314.0
0.7	3	0.00005	10	0.00132	5	2.3	0.00115	2041.5
0.7	3.1	0.00005	10	0.00144	5	2.4	0.0012	1805.5
0.7	3.2	0.00005	10	0.00156	5	2.5	0.00125	1600
0.7	3.3	0.00005	10	0.00169	5	2.6	0.0013	1420.1
0.7	3.4	0.00005	10	0.00182	5	2.7	0.00135	1262.0

TABLE II  
CALCULATED RESULTS FOR CONVERSION GAIN

$V_{ds}$	$R_3$	$I_{dl}$	$g_m(Q3)$	$G_c$	$G_c(dB)$
1.1	1.29E+04	0.000303	0.00055	4.516503	13.09605
1.2	1.06E+04	0.00036	0.0006	4.03397	12.11465
1.3	8.76E+03	0.000423	0.00065	3.625674	11.18777
1.4	7.35E+03	0.00049	0.0007	3.275705	10.3061
1.5	6.22E+03	0.000563	0.00075	2.972399	9.462143
1.6	5.31E+03	0.00064	0.0008	2.707006	8.649786
1.7	4.57E+03	0.000723	0.00085	2.472836	7.863907
1.8	3.95E+03	0.00081	0.0009	2.264685	7.100156
1.9	3.43E+03	0.000903	0.00095	2.078445	6.354769
2	3.00E+03	0.001	0.001	1.910828	5.624432

Stability checking should be the next step in mixer design. Unconditional stability of the circuit is the goal of the mixer designer. Unconditional stability means that with any load present to the output or output of the device, the circuit will not become unstable and will not oscillate. The Rollett Stability Factor (K-factor) represents a quick check for stability at given biasing condition. A sweep of the K-factor

over frequency for a given biasing point should be performed to ensure unconditional stability outside of the band of operation. When K-factor is greater than unity, the circuit will be unconditionally stable for any combinations of source and load impedance. When K-factor is less than unity, the circuit is potentially unstable and oscillation may occur with a certain combination of source and /or load impedance present to the transistor.

#### IV. SIMULATION RESULTS

The biasing analysis and stability checking for the mixer circuit is simulated firstly with Electronics Workbench Multisim8 software. Fig. 4 and Fig. 5 illustrate the simulation results of the stability checking and noise matching at 20 GHz radio frequency of downconversion mixer.

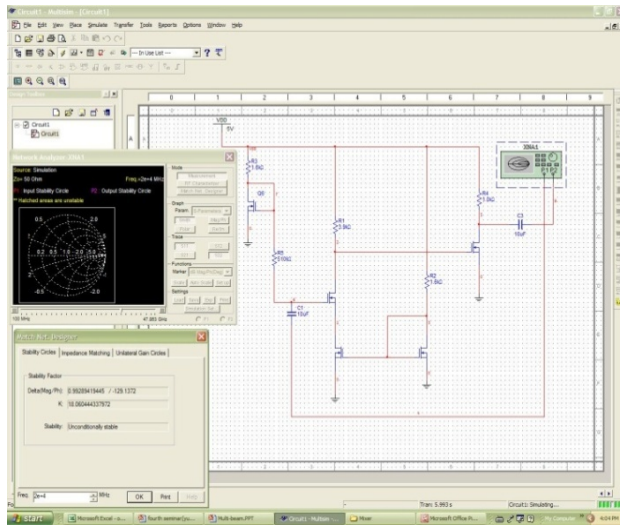

Fig. 4 Stability checking for mixer circuit

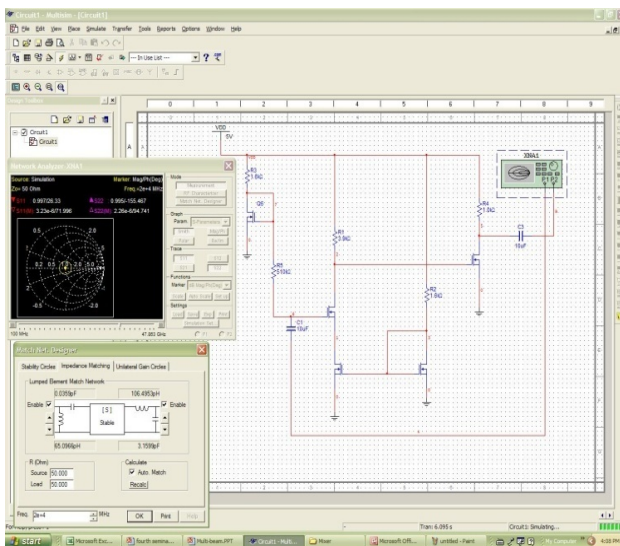

Fig. 5 Impedance matching for mixer circuit

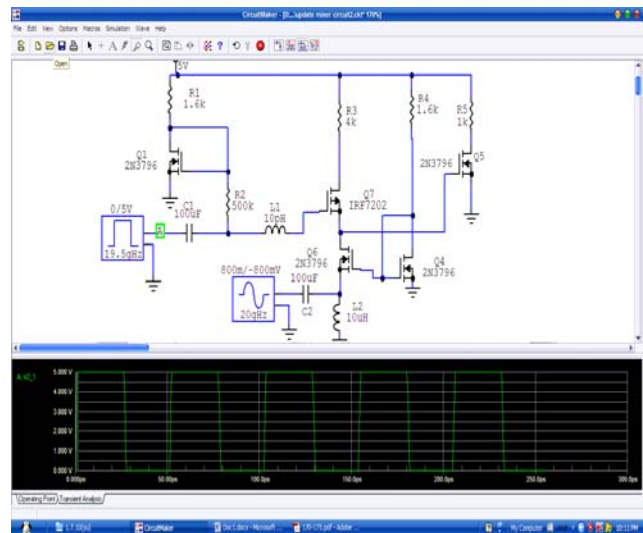

Fig. 6 Local oscillator input of simulated mixer

The 2N6659 transistor was used to simulate as replacement of the transistor acquired in the library source file of the Multisim8 software. The auto matched command of the software will be utilized in order to yield the matching networks when the simulated circuit has been unconditionally stable. Fig. 4 illustrates the stability factor value K is about 18.06. Thus, the system is unconditionally stable with this biasing network. Fig. 5 illustrates the impedance matching at 20 GHz radio frequency for the mixer circuit.

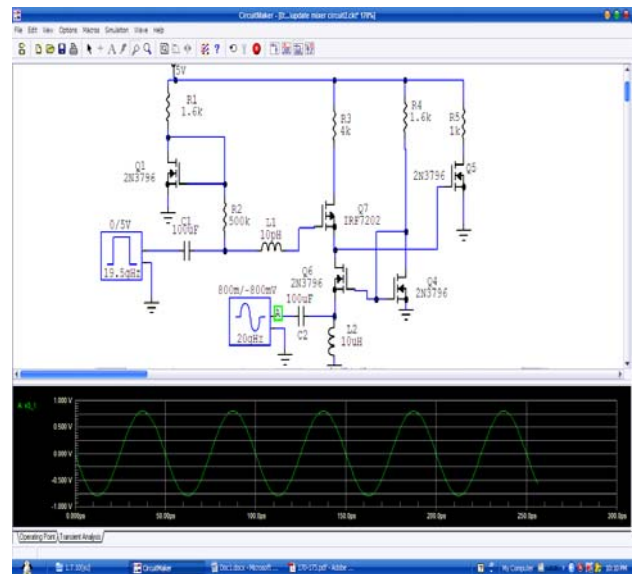

Fig. 7 RF input of simulated mixer with circuit maker 2000

The simulation results indicate that the mixer circuit is acceptable for the 20GHz Ka band applications. Then, the input and output matching network can be carried out and the complete network is yielded in order to simulate with Circuit

Maker2000 software. The 2N3756 field-effect transistors are chosen to run the 20GHz mixer simulation.

Fig. 6 and Fig. 7 illustrates the simulation results of 19.5GHz local oscillator (LO) input and 20GHz radio frequency (RF) input of the proposed mixer schematic diagram. Fig. 8 illustrates the simulation results for the output of the mixer circuit and Fig. 9 also illustrates the view waveform for output result of the mixer circuit.

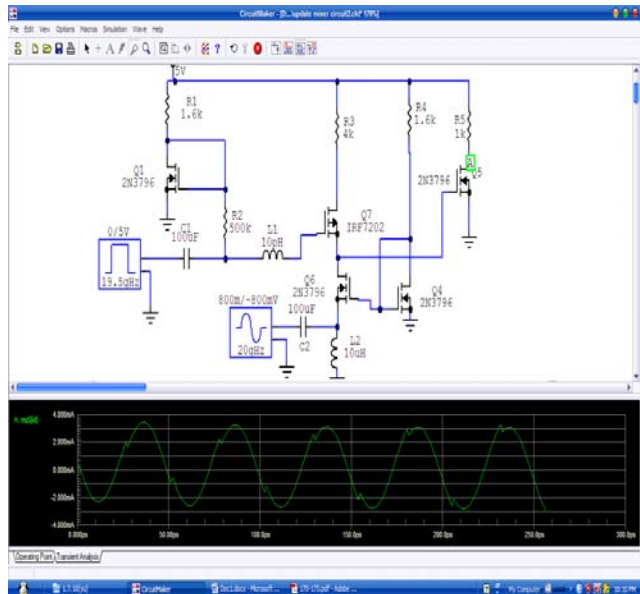

Fig. 8 Output results of simulated mixer

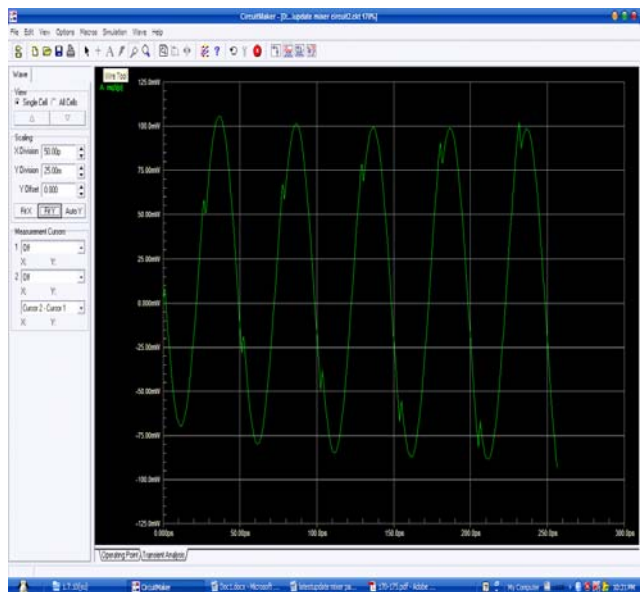

Fig. 9 View waveform for output results of simulated mixer

## V. CONCLUSION

In this paper, the front-end section for satellite receiver has been analysed. This paper illustrates the parameters to implement the mixer design. Conversion gain is the most important parameter in mixer design. The voltage conversion gain was 7.1 dB while the local oscillator signal is at 19.5GHz and RF is 20GHz. It was found that the biasing circuit of mixer has a result of unconditionally stable with Stern stability factor, K value of 18.06. The mixer circuit also has good input and output matching. A single square-law mixer and common source output buffer was used in this mixer circuit.

The paper used in this paper is unbalanced topology because of its lowest noise figure comparing with other topologies. In unbalanced design, noise from the driver stage at the IF can mix with the dc component of the local oscillator signal, and thus increase the noise power at the IF output port. This paper also illustrates the simulation results of input local oscillator signal, RF signal and results of mixing signal with local oscillator signal and RF signal.

## ACKNOWLEDGMENT

The author is greatly indebted to her parents and all of her teachers who have taught her during the whole life.

Especially, the author would like to express her special and respectful gratitude to Dr. Zaw Min Naing, Pro-Rector of Technological University (Maubin), for his constant guidance, invaluable encouragement, and also for giving suggestions, constructive comments and supports given to her during a long period of this study.

The author also would like to thank Dr. Hla Myo Tun, Associate Professor and Head of Electronic Engineering Department, Mandalay Technological University, for his suggestions and comments in doing this research.

The author wishes to acknowledge especially to her co-supervisor, Dr. Kyaw Soe Lwin, Lecturer of Electronic Engineering Department, Mandalay Technological University, for his useful guidance and giving valuable ideas.

## REFERENCES

- [1] Joseph J.Carr, RF Components and Circuits, 1<sup>ed</sup>., British Library.
- [2] Keng Leong Fong, Member, IEEE, and Robert G.Meyer, Fellow, IEEE, "Monolithic RF Active Mixer Design", IEEE TRANSACTIONS ON CIRCUITS AND SYSTEMS-II, ANALOG AND DIGITAL PROCESSING, VOL.46, NO.3, MARCH 1999
- [3] B.Chris, RF Circuit Design, 1<sup>ed</sup>., John Wiley&Son, 2000.
- [4] Rashad M.Ramzan, "Mixer Design", Spring 2010: Radio Frequency Integrated Circuits (TSEK03) Electrical Engineering Department (ISY), Linkoping University.